

- Minimum measuring range 0 to 90° ↯
- Maximum measuring range 0 to 360° ↯
- Contactless electro-optical sensor system
- With 12 Bit D/A-Converter
- Three different signal outputs at option:
0 to 20 mA or 4 to 20 mA or 0 to 10 VDC
- Two adjustment modes to set measuring range, zero point and signal sense
- Robust, heavy duty design

Construction

Flange and case in anodised aluminium - shaft in stainless steel - 12 mm ball-bearings with Nilos ring or radial packing ring seal - code disc in plastic or glass - GaAIAs diode and photo-transistor array - gate array - customer specific micro-processor - multifunctional ASIC - 12 Bit D/A converter - SMD technology.

The Models DAB 58, DAB 65 and DAB 66 have different shaft, flange and case dimensions and different types of electrical connections (for details see page 3).



Functional description and adjustment modes

The DAB Transducers have been derived from the CBE Single-turn-Encoders. They feature an electro-optical sensor system with digital signal processing and a D/A converter. The digital processing unit is designed to resolve any measuring range up to 360° ↯. The 12 Bit D/A-converter transforms these positions into a proportional analogue signal.

If not otherwise specified the transducer will be supplied with a measuring range of 0 to 360° ↯ and CW signal sense, i.e. increasing output signal with view on shaft end. If the user chooses a smaller measuring range, e.g. 270° ↯, there will be an overflow when leaving the specified range. In this event the output signal keeps its maximum level, i.e. 20 mA up to 360° ↯. One of the two following adjustments modes must be specified on order :

- **Version „M“:** For remote control via five multi-functional inputs (MFP) at a 12-way connector. Two contacts are available to indicate zero-point and overflow.
- **Version „S“:** For adjustment in situ via two rotary switches which are located at the rear of the case. Two LED indicate zero point and overflow.

For further details refer to page 2.

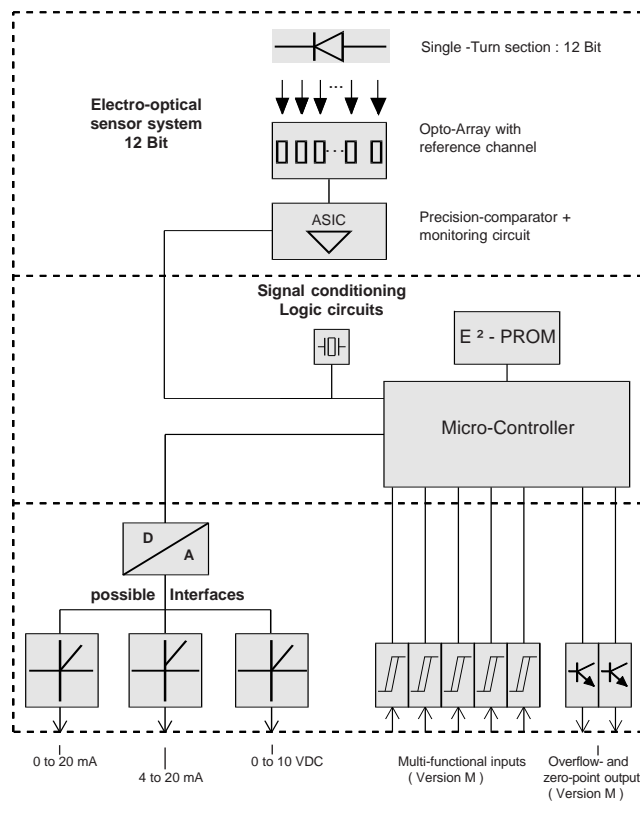

Technical Data

(Valid for both versions unless otherwise stated)

- Sensor system : GaAIAs diode, photo-transistor array, precision comparator
- Disc coding : Gray code
- Setting cycles EEPROM : $\geq 10^6$
- Signal sense: CW or CCW (signal input E6)
- Supply voltage range V_S : + 20 to + 26 VDC
15 \pm 0,5 VDC (optional)
- Supply current I_S : 70 mA typ. / 90 mA max.
(when output current = 0)
- Linearity : 0.025% typ. / 0.05% max. (± 2 LSB)
12 Bit monotony warranted
- Temperature drift : 0.0015 % /K typ.

Current output

- Accuracy
 - at starting point 0 mA : 0 mA \pm 5 μ A typ / \pm 15 μ A max.
 - 4 mA : 4 mA \pm 5 μ A typ / \pm 15 μ A max.
 - at end point 20 mA : 20 mA \pm 5 μ A typ / \pm 15 μ A max.
- Load resistance : 0 to 500 Ω at $V_S = 20$ to 26 VDC
0 to 1000 Ω at $V_S = 22$ to 26 VDC

Voltage output

- Accuracy
 - at starting point 0 V : 0 V \pm 2.5 mV typ. / \pm 7.5 mV max.
 - at end point 10 V : 10 V \pm 2.5 mV typ. / \pm 7.5 mV max.
- Output current : 5 mA max. When load resistance > 2k Ω (short circuit proof)

Version "M"

- Multi functional inputs: Signal input E2
- Zero-point output: Open collector / output B
- Overflow output: Open collector / output B

Signal input E2

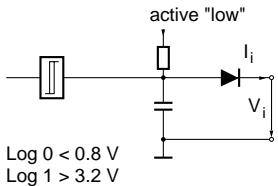

Signal output B

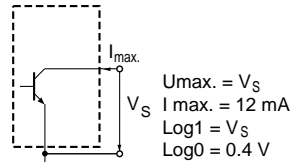

Version "S"

- 2 Rotary switches: 6 functions
- Zero-point signal: LED
- Overflow signal: LED

Rear View of version "S"

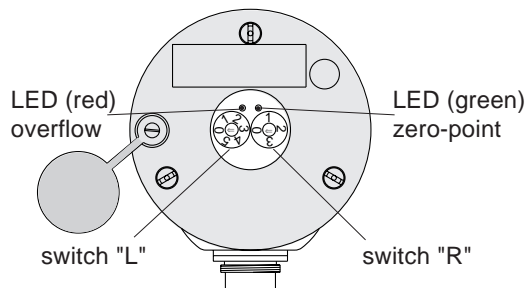

Electrical connections

- Version "M": Round connector 12-way, (IP65), radially on case
- Version "S": Round connector 4-way, (IP65), radially on case

Mechanical Data

- Operating speed : 3000 rpm max. (continuous)
4000 rpm max. (short period)
- Operating torque : $\leq 5 \text{ Ncm}$ (8 Ncm - DAB 66)
- Wind-up torque : $\leq 1 \text{ Ncm}$ (4 Ncm - DAB 66)
- Angular acceleration : $10^5 \text{ rad/s}^2 \text{ max.}$
- Inertial mass of rotor : 50 gcm^2
- Permissible axial and radial shaft load : 250 N max.
- Bearing life expectancy : 10^9 turns

Environmental Data

- Operating temperature range : - 20°C to + 60°C
- Storage temperature range : - 25°C to + 70°C
- Permissible rel. humidity : 85% without condensation
- Resistance to shock : 200 m/s² ; 11 ms (DIN IEC 68)
- Resistance to vibration : 5 Hz ... 1000 Hz ; 100 m/s² (DIN IEC 68)
- Protection class (DIN 40050)
 - DAB 58, 65 and 105 : IP 65 (Nilos ring)
 - DAB 66 : IP 66 (radial packing ring)
- Mass : 0.5 kg

Adjustment operations

The following adjustment operations can be carried out in situ when the transducer is mounted and coupled to its driving device:

- **Measuring range**
 - Setting of zero-point at specified mechanical position
 - Setting of end-point at specified mechanical position
- **Adjustment of zero-point** without changing of specified measuring range
- **Adjustment of measuring range** without changing of specified zero-point
- **Signal sense** either CW or CCW
- **The basic output feature**, i.e. 360° measuring range and CW signal sense, can be reproduced whenever required.

For further details please refer to the operating instruction sheet which is supplied with each item.

Order code format

DAB 58 - M 360 W A 01

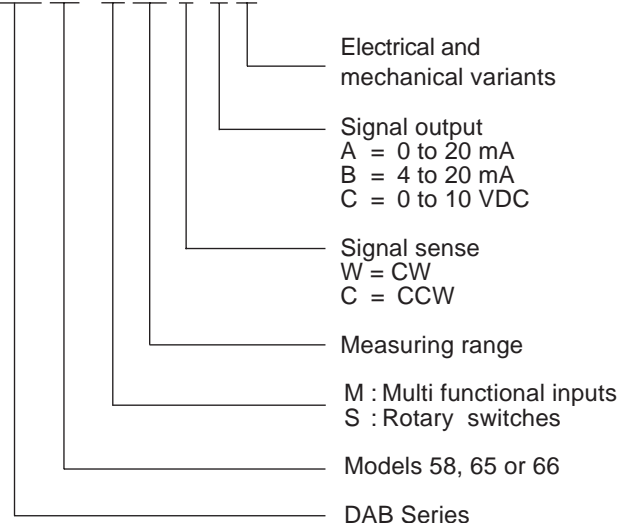

Dimensions in mm

Model DAB 58 with synchro-flange

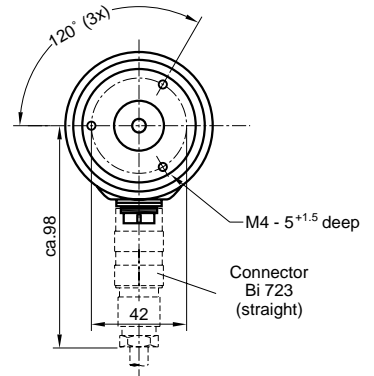
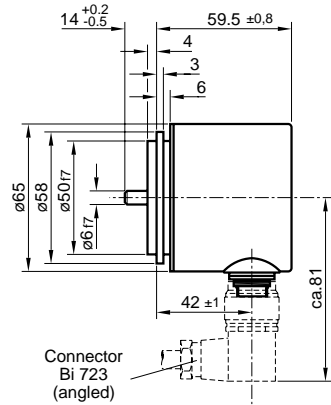

Model DAB 65 with synchro-flange

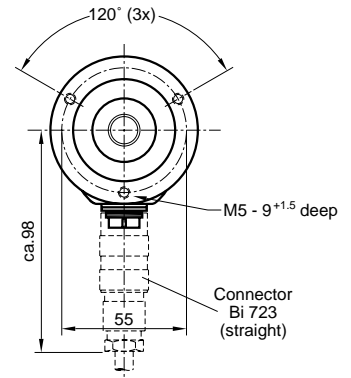
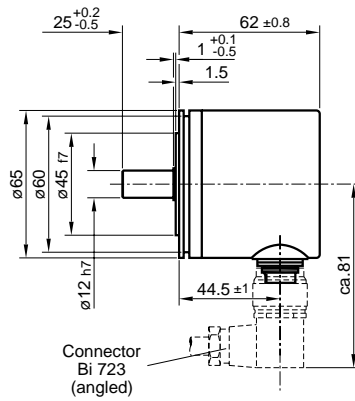

Model DAB 66 with clamping flange, shaft with flat

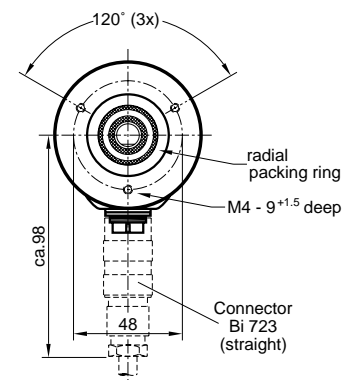
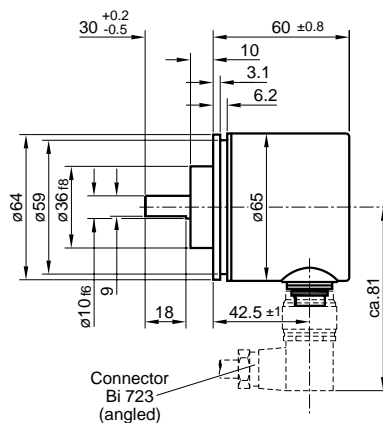

Accessories : Straight connectors are included in the supplied items. Angled connectors are supplied on order. Couplings can be supplied as per Data Sheet KW 10112.

Version "M" : 12-way connector
Version "S" : 4-way connector

Table of multi-functional inputs (mfp) for version "M"

Function		MFP4	MFP3	MFP2	MFP1	MFP0
Adjustment of standard values		0	1	0	1	0
Adjustment of output signal sense	(CW)	0	1	0	0	X
	(CCW)	0	1	1	1	0
Adjustment of measuring range:	(zero)	1	0	0	1	0
	(max.)	1	0	0	0	X
Zero point adjustment:	- increase output value	1	0	1	1	0
	- decrease output value	1	0	1	0	X
Changing of measuring:	- increase range value	1	1	0	1	0
	- decrease range value	1	1	0	0	X
End of adjustment						
Normal transducer function		1	1	1	1	1

CW = Increasing output signal when turning the shaft clockwise

CCW = Increasing output signal when turning the shaft counter - clockwise

Timing diagrams

Adjustment of measuring range
 Adjustment of standard values
 Adjustment of output signal sense

Zero point adjustment
 Changing of measuring

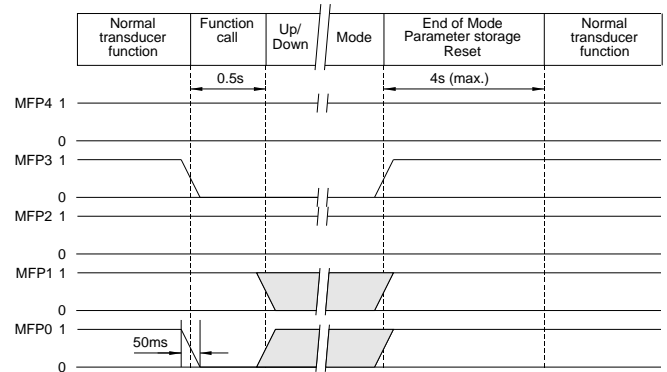
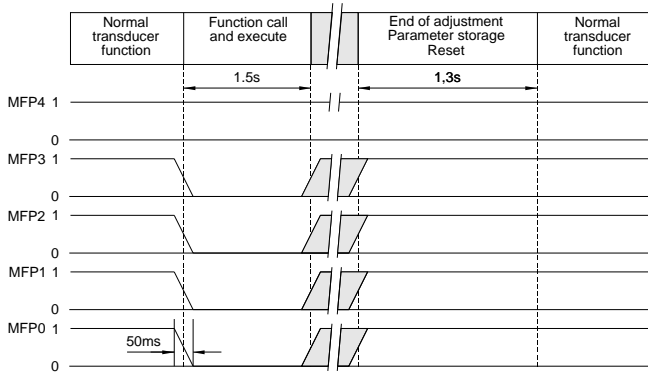

Table of switch functions for version "S"

Function		switch L	switch R
Adjustment of standard values		5	1
Adjustment of output signal sense	(CW)	4	1
	(CCW)	4	3
Adjustment of measuring range:	(zero)	3	1
	(max.)	3	3
Zero point adjustment:	- increase output value	2	1
	- decrease output value	2	3
Changing of measuring:	- increase range value	1	1
	- decrease range value	1	3
End of adjustment			
Normal transducer function		0	0

First select function by switch L then execute function by switch R.

After execution use switch R before switch L to select function "end of adjustment".