

SR1M

Industrial Low Cost String Pot

User Scalable 4...20 mA Output Signal
 0-125, 0-175 inch Full Stroke Range Options
 Designed for Outdoor / Wet environments

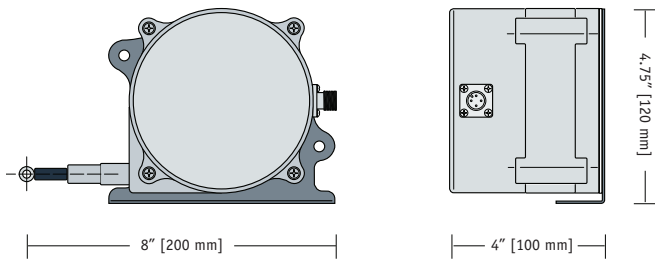
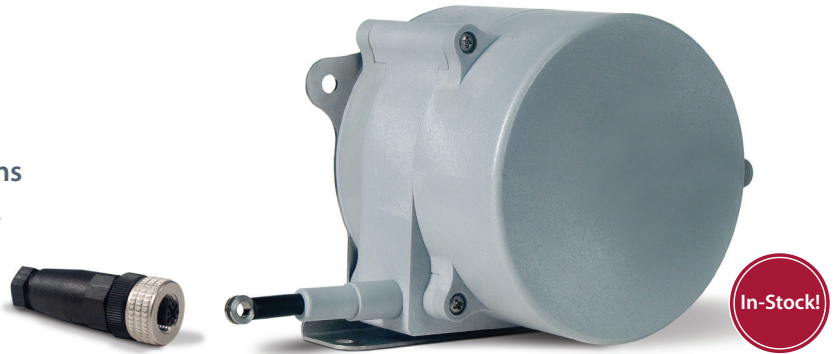

SPECIFICATIONS

Input Voltage	10-30 VDC
Accuracy, full stroke range \geq 10 inches (254 mm)	.5% FS.
Accuracy, full stroke range $<$ 10 inches (254 mm)	consult factory
Repeatability	.1% FS.
Resolution	.0015% FS.
Output Signal Update Rate	1 msec
Maximum Velocity	80 inches (2 meters) per second
Maximum Acceleration	10 G (retraction)
Measuring Cable Tension	23 oz. (6,4 N) \pm 30%
Sensor	plastic-hybrid precision potentiometer
Cycle Life	250,000 (potentiometer)
Enclosure	polycarbonate
Measuring Cable	.034-inch dia. nylon-coated stainless
Electrical Connection	M12 Connector (mating plug included)
Weight	2.5 lbs. (1.3 Kg)

Max. Full Stroke Range. SR1M-125	125 inches (3175 mm)
Max. Full Stroke Range. SR1M-175	175 inches (4445 mm)
Minimum Full Stroke Range	1 inch (25 mm)
Output Signal Settings	4...20 mA, 20...4 mA
Environmental Suitability	NEMA 6, IP67
Operating Temperature	-40° to 185° F (-40° to 85° C)

The SR1M is part of a series of rugged, low-cost, high performance string pots built for wet environments and outdoor applications. Designed for the rigors of outdoor construction equipment or the demands of a factory floor, the SR1M is the perfect low-cost solution for OEM and stocking distributors.

What sets this sensor apart from other string pots, is the internal programmable digital circuitry that gives the customer a one-size-fits-all approach for many applications. The SR1M ships factory calibrated to the full stroke range but the output signal can be easily re-scaled to match any stroke down to 1 inch (25 mm).

Ordering Information

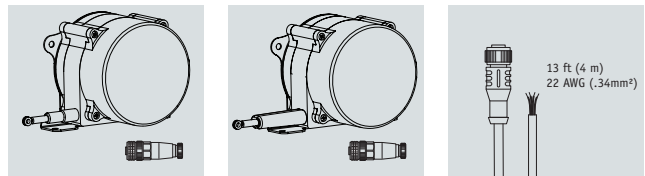

Part No. SR1M-125	Part No. SR1M-175	Part No. 9036810-0040
-----------------------------	-----------------------------	---------------------------------

Factory calibrated to 125 inches, M12 field-installable connector, IP67 environments, mounting bracket included

Factory calibrated to 175 inches, M12 field-installable connector, IP67 environments, mounting bracket included

OPTIONAL CORDSET for short-run connections, a 13-ft. cordset with 4-pin M12 connector

Electrical Connection

i/o signal	connector pin	colorcode (cordset)
10...30 vdc	1	brown
n/c	2	white
output signal	3	blue
n/c	4	black

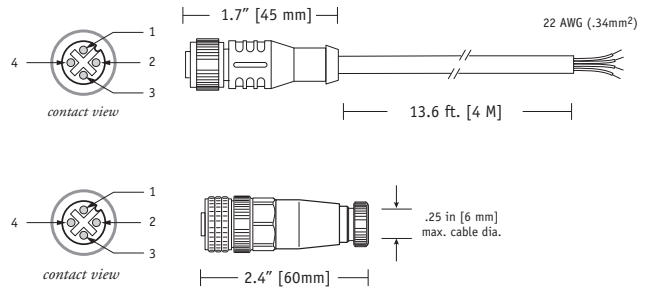

Cable Exit Direction Options

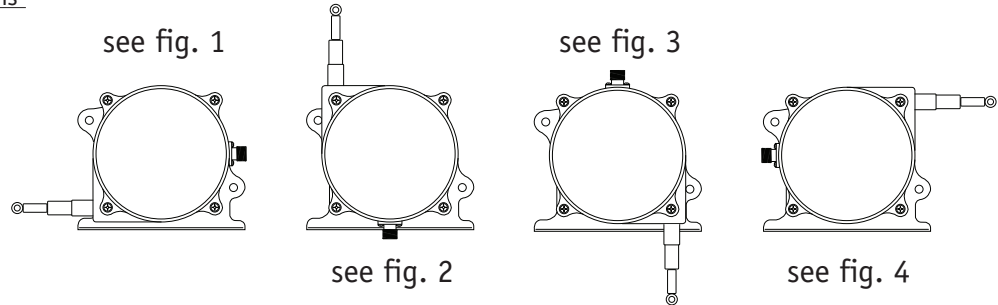

Changing the Measuring Cable Exit and Electrical Connector Direction

Changing Measuring Cable Exit

To change the direction of the measuring cable, remove the 4 mounting bracket screws and rotate bracket to one of four available positions. See figures 1 - 4 on the following pages for mounting dimensions.

Changing Electrical Connector Direction

To change the position of the electrical connector, remove the 4 rear cover screws and carefully separate rear cover from the sensor body.

Rotate the rear cover to desired position being careful to not tangle the wiring harness that runs to the connector.

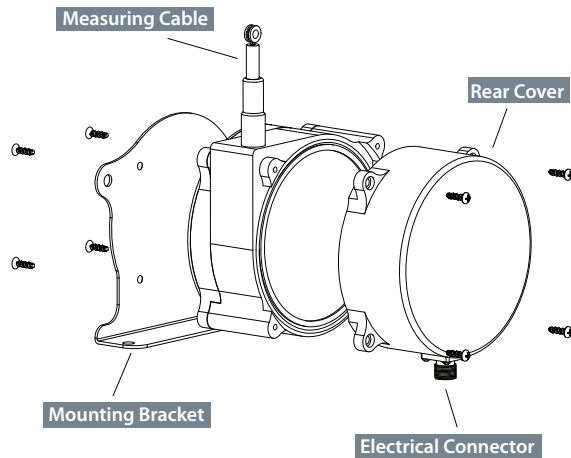

Factory Calibrated Stroke Range

The full scale output signal is set at the factory to the maximum full stroke range of the sensor. The ZERO point (output = 4mA) is set at the beginning* of the stroke range (0 inches) and the SPAN point (output = 20mA) is set to the end of the range (125 inches or 175 inches depending on model).

**Important* — The ZERO point is set at the factory with the measuring cable pulled out .125 inches from full retraction. If the measuring cable becomes fully retracted at any time when the sensor is under power, the output signal will begin to fluctuate. This is normal and fluctuation will stop as soon as the cable is extended greater than .125 inches.

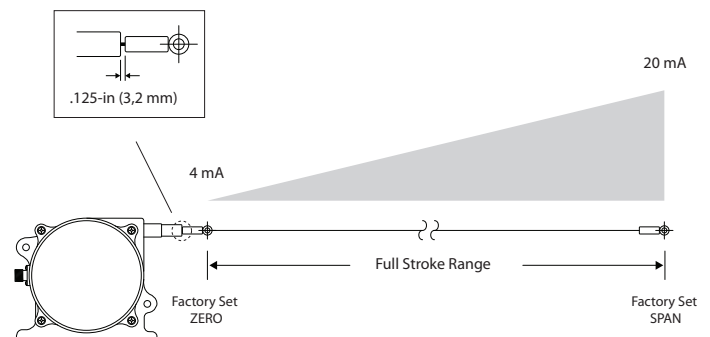

This is for the factory setting only and the ZERO may be reprogrammed at full retraction at any time.

Internal Controller Board

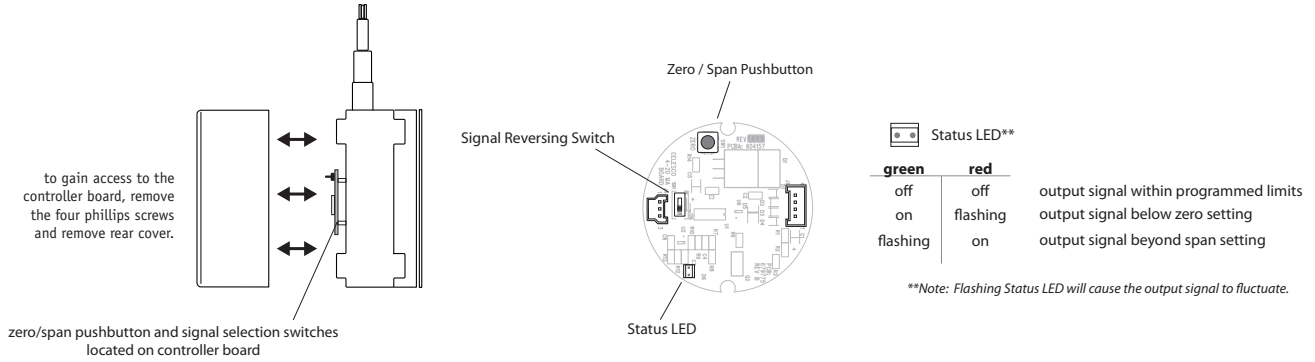

Changing Output Signal

Reprogramming ZERO and SPAN:

The ZERO and SPAN points have been preset at the factory but can easily be changed to match any desired stroke within the full stroke limits of the sensor. To reprogram the SR1M to your own settings, remove the rear cover to gain access to the internal controller board. Locate the push-button on the circuit board and follow the instructions below.

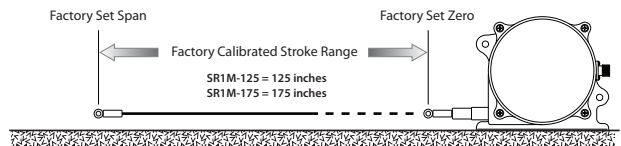

Please note that ZERO and SPAN points can be set independently. You can set one without setting the other. This operation must be performed with the sensor under power. *Important: when you are finished, disconnect power for at least 2 seconds to permanently set your new settings.*

Setting Span:

Set the cable to the desired SPAN point then depress and hold the button until the STATUS LED begins to flash RED. Release the button when the LED begins to flash RED (not GREEN). The flashing will then slow down to about two-second intervals to indicate that the SPAN value is being set into memory. When completed, the STATUS LED will turn off.

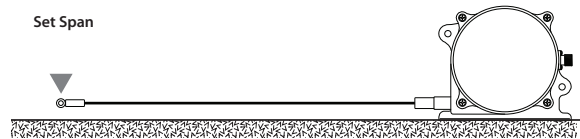

Setting Zero:

Set the cable to the desired ZERO point and then depress and hold the button until the STATUS LED begins to flash GREEN. Release the button when the LED begins to flash GREEN (not RED). The flashing will then slow down to about two-second intervals to indicate that the ZERO value is being set into memory. When completed, the STATUS LED will turn off. Remove power for 2 seconds then reconnect.

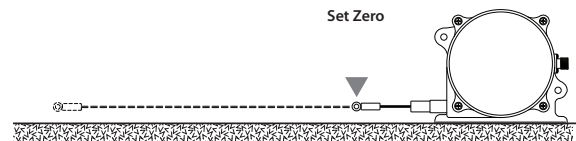

Reversing the Output Signal:

output signal options (mA)	zero	span	switch settings
	4 ... 20	20 ... 4	off
		on	

The SR1M leaves the factory set with a 4...20 mA full scale output signal. The signal can be reversed (see illustration) by simply changing a dipswitch located on the controller board.

This may be done without resetting the "zero" and "span" points.

Remove the rear cover to gain access to the board.

Fig. 1 - Outline Drawing (as shipped)

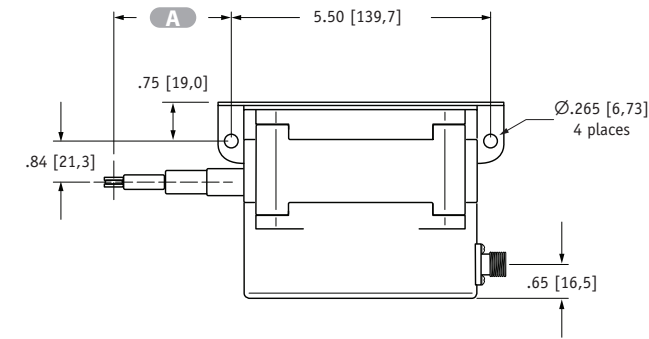

Model	A	B
62-inch	2.00 ±.13 [50,8 ±3,3]	2.37 ±.13 [60,22 ±3,3]
125-inch	2.87 ±.13 [72,8 ±3,2]	3.24 ±.13 [82,2 ±3,2]

Cable Guide Detail

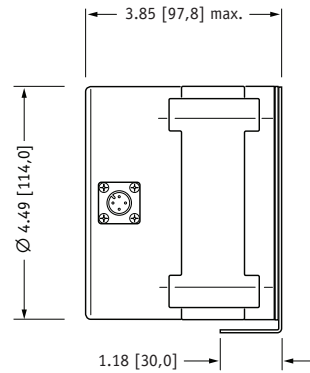
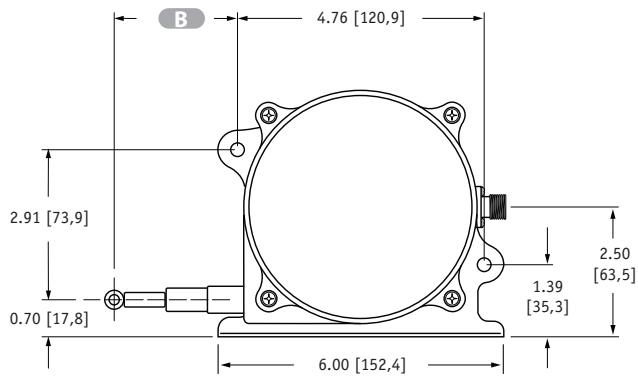
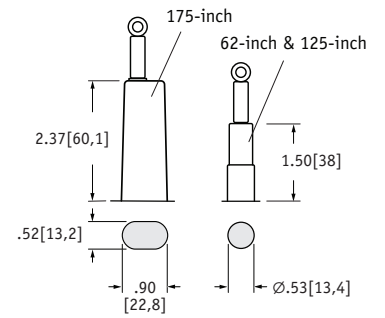

Eyelet Detail

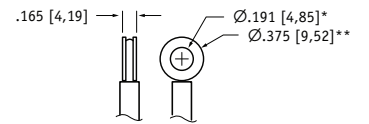

units are in inches [mm] tolerances are ± .04 [1,0] unless otherwise noted

* tolerance = +.005 -.001 [+13 -.03]
** tolerance = +.005 -.005 [+13 -.13]

Fig. 2 - "Up" Cable Exit Direction

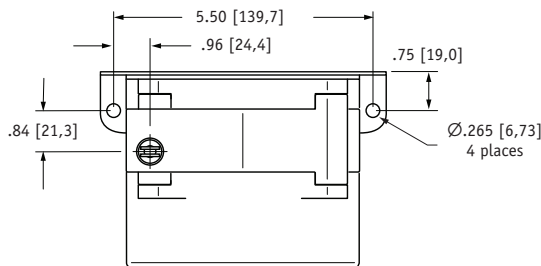

Model	A
62-inch	3.64 ±.13 [92,5 ±3,3]
125-inch	4.54 ±.13 [115,3 ±3,3]

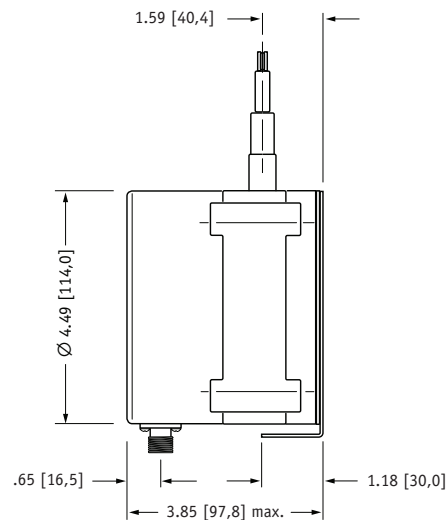
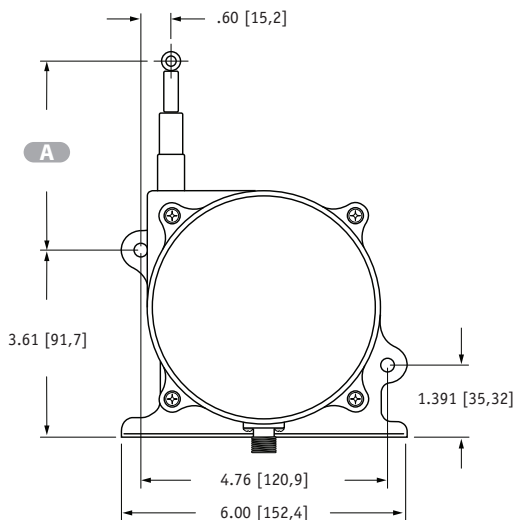

Fig. 3 - "Down" Cable Exit Direction

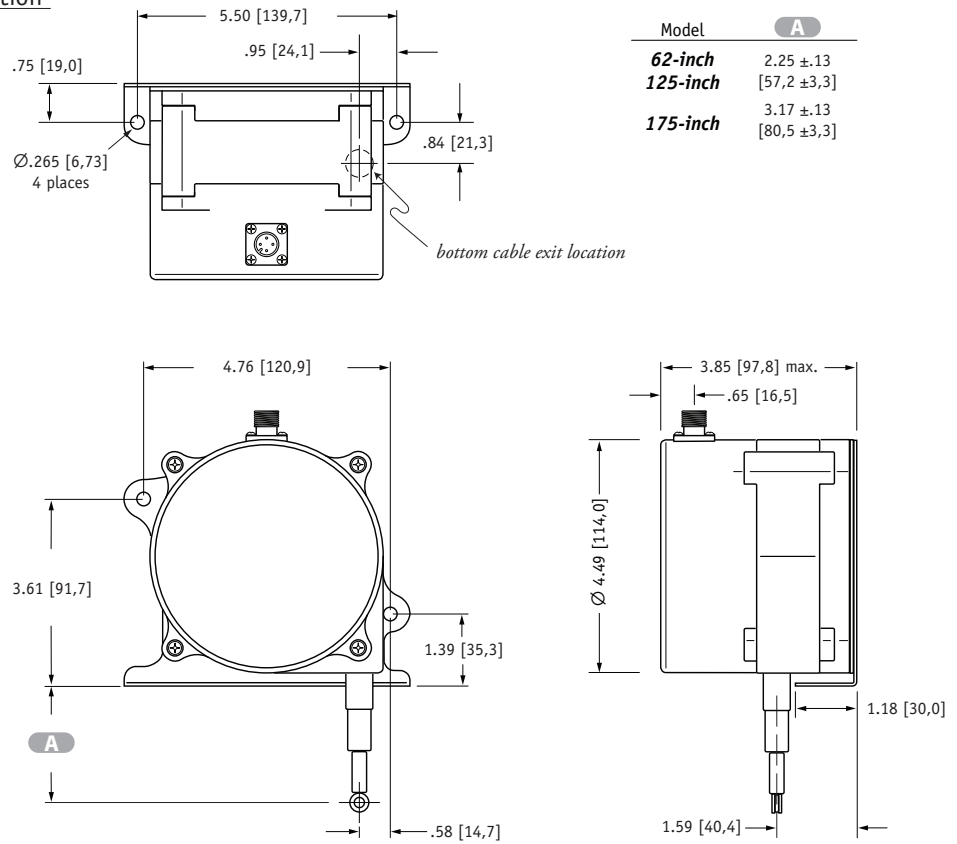
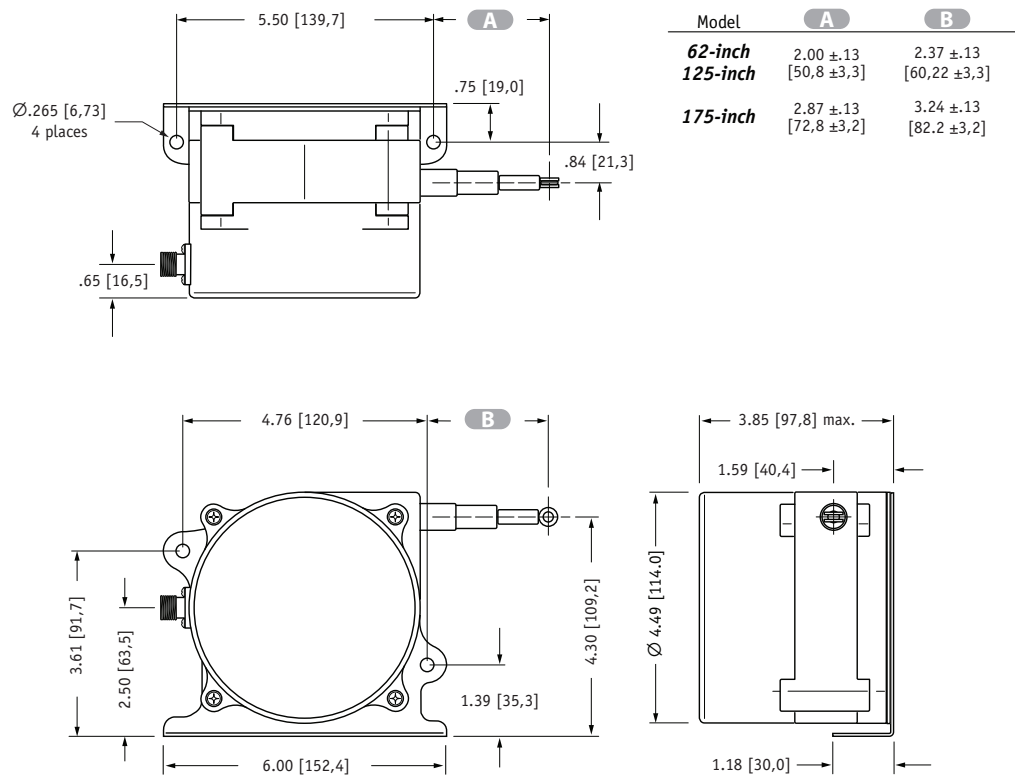

Fig. 4 - "Rear" Cable Exit Direction



version: 3.0 last updated: February 28, 2012